

DIM105 Constant Voltage Triac Dimmer



Welcome to use our company's DIM105 Triac dimmer, this dimmer is a constant voltage dimmer, output current is 15A max. Adopt the advanced microcomputer control technology, and use the advanced electronic components. This dimmer has stable performance and high quality. It's can be used widely at building, hotel, KTV and home.

1 Feature :

- ◆ Triac dimming, input dimming signal:AC40V~220V
- ◆ Support all the triac dimming system, such as Lutron, Clipsal,Dynalite
- ◆ Single channel output, output current 15A max
- ◆ The dimming curve smooth, no flicker
- ◆ 0-100% brightness control

2 Technical parameter:

Input Voltage	DC 12-24V
Dimming Voltage	AC 40-220V
Output Current	15A max
Output Power	12V:180W max 24V:360W max
Work Temp.	-20 - 50℃
Product Size	167(L)×52(W)×24(H) mm
Pack Size	175(L)×57(W)×30(H) mm
N.W.	83.5g
G.W.	114g

3 Product Size:

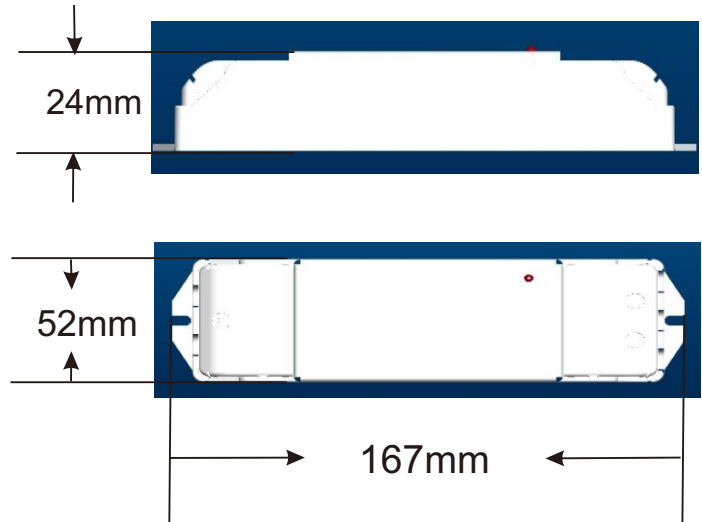

4 Wiring instruction:

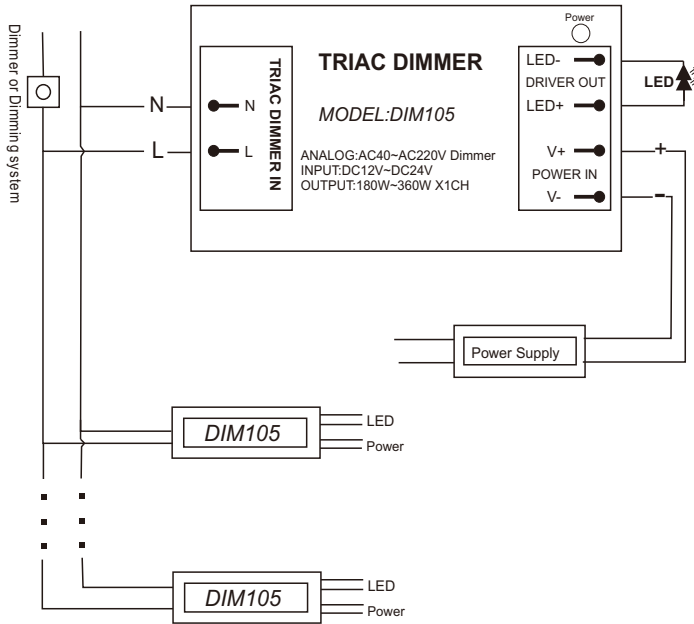

Remark:

AC40V-AC220V dimming signal input can get 0%-100% brightness output, and the dimming curve smoothness is proportional to the input dimming signal. If the brightness can't go to 0%, please check the AC40V-AC220V dimmer whether can get to the lowest dimming voltage. If the brightness can't go to 100%, please check the input voltage whether can get to the highest voltage.

5 Installation Notes

1. Input voltage must be fit the production work voltage
2. Do not overload
- 3 Before commissioning of the power , should ensure that all wiring is correct before electricity.
4. If failure, do not privately maintenance, please contact the supplier