

## PX0508-OLED DMX512 Decoder&Master



5 channels output, the maximum current of 8A /ch for RGBWY decoder, up to 960W  
 OLED Screen and touch button, more convenient operation  
 Can be used as stand alone DMX Master controller  
 8 bit / 16 bit resolution optional  
 Multiple dimming curve: (0.1~9.9), liner, log

### Summary

Welcome to use PX series DMX512/RDM decoder & driver. PX series adopt the advanced micro-computer control technology and converted the DMX512,RDM/2009 digital signal widely used in international to the PWM control signal. 1~5 channels output for option and each channel able to achieve 256 or 65536 gradations of controlling, and also it can be used as the connector of PC digital light controller and analog light modulator. It is mainly used for the controlling of buildings & lights applied LED.

### Product Features

- 5 channels output, the maximum current of 8A /ch for RGBWY decoder, up to 960W
- Can be used as stand alone DMX Master controller
- OLED Screen and touch button, more convenient operation
- 27 sence modes built-in, with speed and brightness adjust function
- 5 kinds of optional: DIM, CT, RGB, RGBW, RGBWY
- 2 kinds of DMX ports: XLR-5, RJ45
- Short-circuit protection, overload protection, over-temperature protection
- Fast self-testing function
- 8 bit / 16 bit resolution optional(master mode support 8bit only)
- Multiple dimming curve: (0.1~9.9), liner, log
- Meets DMX512/1990,RDM /2009 protocol
- Supported RDM parameters:
  - DISC\_UNIQUE\_BRANCH
  - DISC\_MUTE
  - DISC\_UN\_MUTE
  - DEVICE\_INFO
  - SOFTWARE\_VERSION\_LABEL
  - DMX512/RDM\_START\_ADDRESS
  - IDENTIFY\_DEVICE
  - MANUFACTURER\_LABEL
  - SUPPORTED\_PARAMETERS

**Technical Parameters**

Model : PX0508-OLED  
 Input Signal : DMX512 1990/RDM 2009  
 Input Voltage : 12~24V  
 Output Voltage : 12~24V  
 Output Current : 8A\*5CH MAX. 40A  
 Output Power : (0~96W...192W)\*5CH MAX. 960W  
 Control Mode : DIM/CT/RGB/RGBW/RGBWY  
 Dimming Curve : 0.1~9.9/Liner/Log  
 Grey Level : 8Bit (256 levels) / 16Bit (65536 levels)  
 Protection : Short-Circuit / Over Load / Over Temperature  
 Dimension : 125\*93\*36 mm (L \* W \* H)  
 Packing Size : 145\* 104\*42 mm (L \* W \* H)  
 G.W. : 365 g  
 Operation Temperature : - 20 - 50 C  
 Relative humidity : 20% - 90% RH

**Dimension(mm)**

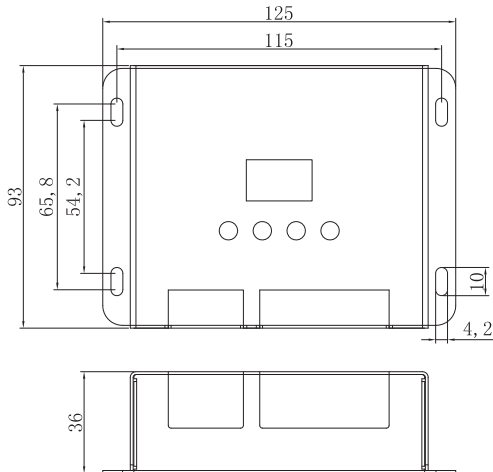

**Interface Description**

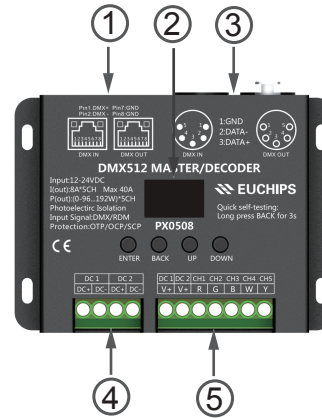

- (1) RJ45 DMX/RDM Signal input and output
- (2) OLED Screen
- (3) XLR-5 DMX/RDM Signal input and output
- (4) Power input interface
- (5) Green terminal LED Lamps connection

**OLED Screen Description**

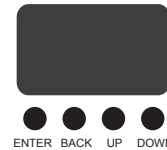

Button Name	Function
Enter	Enter Button ( focus on the option menu pointed by the cursor and enter the state of this option menu.
BACK	Back Button, return to the previous menu; exit the state of this option
Up	Move the cursor up, change the state of the option
Down	Move the cursor down; change the state of the option

The product restores the default initial page which shows the current parameter information and working status when power on again. Please press "ENTER" to homepage. If there is no operation in 1 minute, the OLED screen will restore the initial page.

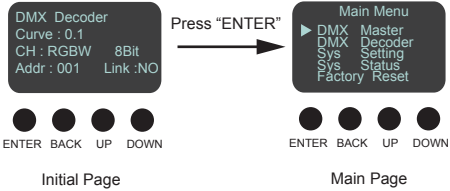

**DMX Master**

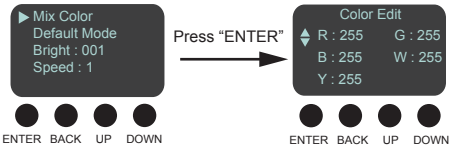

**Mix color**

RGBWY Brightness setting  
 R : 0-255 adjustable  
 G : 0-255 adjustable  
 B : 0-255 adjustable  
 W : 0-255 adjustable  
 Y : 0-255 adjustable

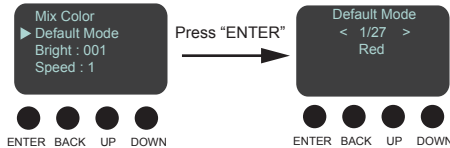

**Default Mode (RGB/RGBW/RGBWY)**

Built-in mode : 1-27 modes for option, all 27 modes

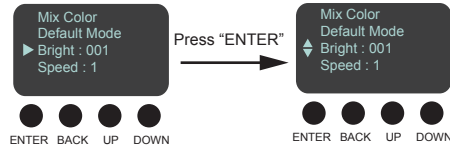

**Bright**

Press "up" or "down" key  
 0-255 adjustable

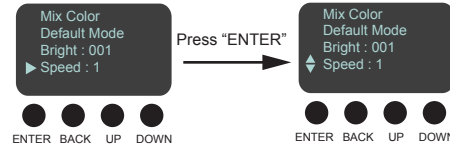

**Speed**

Press "up" or "down" key  
 1-100 adjustable

**Default Mode (RGB/RGBW/RGBWY)**

NO.	Mode	NO.	Mode
1	Red	15	GB Ramp
2	Green	16	RGB Ramp
3	Blue	17	ALL Ramp
4	Yellow	18	RG_Gradient
5	Cyan	19	RB_Gradient
6	Purple	20	GB_Gradient
7	White	21	RGB_Gradient
8	RG Jump	22	ALL_Gradient
9	RB Jump	23	RG_Chase
10	GB Jump	24	RB_Chase
11	RGB Jump	25	GB_Chase
12	ALL Jump	26	RGB_Chase
13	RG Ramp	27	ALL_Chase
14	RB Ramp		

**Default Mode (CT)**

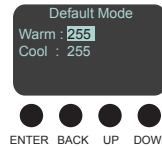

**CT Brightness setting**

Press "up" or "down" key  
 Warm : 0-255 adjustable  
 Cool : 0-255 adjustable

**Default Mode (DIM)**

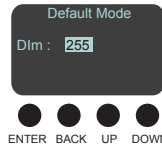

**DIM Brightness setting**

Press "up" or "down" key  
 Dim : 0-255 adjustable

**DMX Decord**

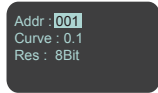

**DMX Address setting**

Press "up" or "down" key to set DMX Adress

Address : 1-511 adjustable

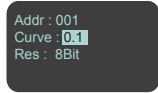

**Dimming Curve setting**

Press "up" or "down" key to set dimming curve

Curve : 0.1~9.9  
Linear  
Log

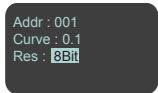

**Resolution setting**

Press "up" or "down" key to set resolution

Resolution : 8Bit  
16Bit



**Sys Setting**

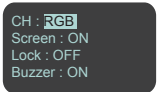

**Output setting**

Press "up" or "down" key to set output channel

CH : DIM  
CT  
RGB  
RGBW  
RGBWY

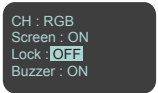

Lock : ON  
Screen will be locked if unmaned operation for 1 min , press "Enter" key for 3s to unlock



**Sys Status**

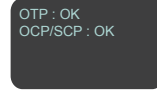

**OTP/OCP/SCP Status**

When you use DMX decoders after the wiring completed, you can check the short circuit, over current, over load problems in this page once the fault occurs and the "OK" will switch to "Warning" on the screen.



**Factory Reset**

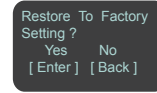

**Self -testing**

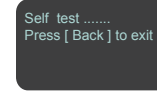

**Quick self-testing**

Press "BACK" for 3s on any page

**Wiring Diagram**

Connecting LED lights:

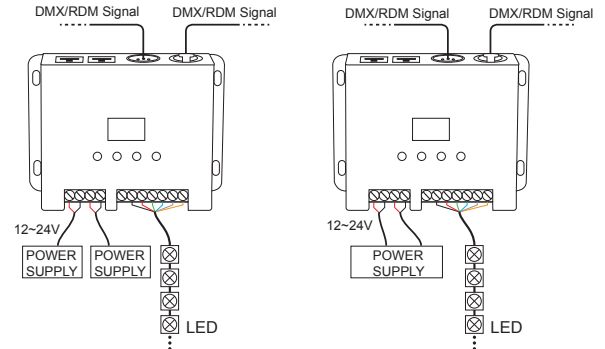

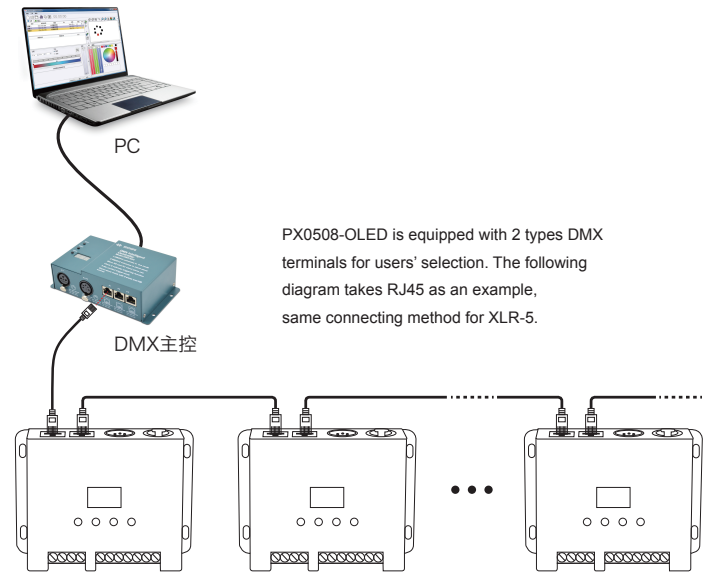
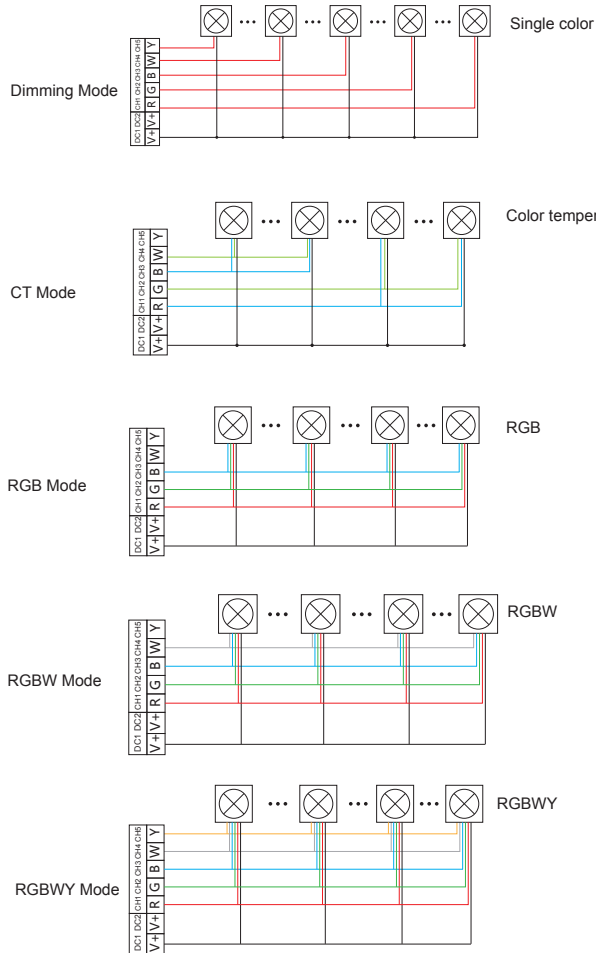

PX0508-OLED is equipped with 2 types DMX terminals for users' selection. The following diagram takes RJ45 as an example, same connecting method for XLR-5.

An amplifier is needed when more than 32 decoders are connected, signal amplification should not be more than 5 times continuously.

If the recoil effect occurs because of longer signal line or bad line quality, please try to connect 0.25W 90-120Ω terminal resistor at the end of each line.

The connection diagram of 2 kinds of DMX/RDM terminals:

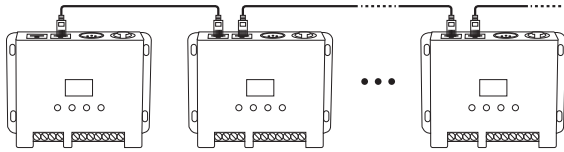

RJ45 Connected in parallel

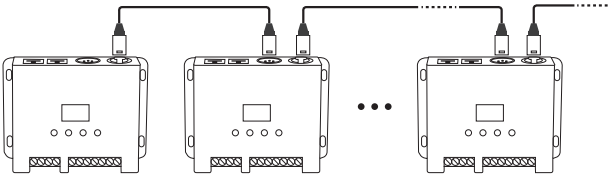

XLR-5 Connected in parallel

Address setting table

Mode	DIM	CT	RGB	RGBW	RGBY
Address Quantity	1	2	3	4	5
Resolution	8bit	8bit	8bit	8bit	8bit
Channel	1	001	001	001	001
	2	001	002	002	002
	3	001	001	003	003
	4	001	002	003	004
	5	001	002	003	004

Mode	DIM	CT	RGB	RGBW	RGBY	
Address Quantity	2	4	6	8	10	
Resolution	16bit	16bit	16bit	16bit	16bit	
Channel	1	001 002	001 002	001 002	001 002	001 002
	2	001 002	003 004	003 004	003 004	003 004
	3	001 002	001 002	005 006	005 006	005 006
	4	001 002	003 004	005 006	007 008	007 008
	5	001 002	003 004	005 006	007 008	009 010